



GTA 2X8 L.A.

**manual de uso
user manual**

An updated .pdf version of this manual is always available at www.prodgsystems.com

Indicaciones de seguridad

Leer antes de usar el sistema y guardar para su uso posterior

PRO DG SYSTEMS® LE DA LAS GRACIAS POR HABER ADQUIRIDO ESTE SISTEMA DE SONIDO PROFESIONAL TOTALMENTE DISEÑADO, FABRICADO Y OPTIMIZADO EN ESPAÑA EXCLUSIVAMENTE CON COMPONENTES EUROPEOS Y LE DESEAMOS QUE DISFRUTE CON SU ALTA CALIDAD Y PRESTACIONES.

• El sistema ha sido diseñado, fabricado y optimizado por Pro DG Systems® en un estado técnicamente perfecto. Para conservar este estado y asegurar el correcto funcionamiento el usuario ha de respetar las siguientes indicaciones y advertencias de este manual.

LA FIABILIDAD, SEGURIDAD Y RENDIMIENTO DEL SISTEMA ESTAN UNICA Y EXCLUSIVAMENTE GARANTIZADAS POR PRO DG SYSTEMS CUANDO:

- El montaje, manipulación, reajuste y los cambios o reparaciones hayan sido realizados por Pro DG Systems.
- La instalación eléctrica cumpla con la determinación IEC (ANSI).
- El sistema se use según las indicaciones de uso.

ADVERTENCIA:

• Si se destapan protecciones o se retiran piezas del chasis, exceptuando las que se puedan retirar manualmente, se pueden dejar piezas al descubierto que sean conductoras de tensión.

• Cualquier ajuste, manipulación, optimización o reparación del sistema debe ser realizada única y exclusivamente por Pro DG Systems. PRO DG SYSTEMS NO SE RESPONSABILIZA DE NINGUN DAÑO QUE SUFRA EL SISTEMA A CAUSA DE UNA MANIPULACION, AJUSTE, OPTIMIZACION O REPARACION REALIZADA POR PERSONAL NO AUTORIZADO POR PRO DG SYSTEMS.

• Niveles elevados de intensidad de sonido pueden ser causa de daños auditivos se debe evitar acercarse demasiado a altavoces que funcionen a altos niveles, de lo contrario se deben usar protecciones auditivas.

ACOMETIDA A LA RED:

- El sistema está fabricado para un funcionamiento continuo.
- La tensión de funcionamiento ajustada tiene que coincidir con la tensión de la red del lugar.
- La conexión a la red eléctrica se efectuará con la fuente de alimentación o cable de red que se entreguen con el sistema.
- Fuente de alimentación: una línea de conexión dañada no se puede sustituir. La fuente de alimentación no se puede volver a poner en funcionamiento.
- Evite una conexión de la red eléctrica a distribuidores con muchas tomas de corriente.
- El enchufe para el suministro de corriente tiene que estar cerca del aparato y ser de fácil acceso.

SITUACION:

- El sistema debe situarse en una superficie limpia y totalmente horizontal.
- El sistema no puede estar expuesto a ninguna sacudida o movimiento durante su funcionamiento.
- Evite el contacto del sistema con el agua y superficies húmedas.
- Procure que el sistema disponga de la suficiente ventilación y no bloquee ni tape ninguna abertura de ventilación.
- Evite la exposición directa con el sol así como la proximidad a fuentes emisoras de calor o radiación.
- Si el sistema sufre un cambio extremo de temperatura es posible que afecte a su funcionamiento, antes de poner en marcha el sistema espere que éste haya adquirido la temperatura ambiental.

Safety Indications

Please read it before use the system and keep for later use

PRO DG SYSTEMS® GIVES YOU THANKS FOR ACQUIRE THIS PROFESSIONAL SOUND SYSTEM FULLY DESIGNED, MANUFACTURED AND OPTIMIZED IN SPAIN, EXCLUSIVELY WITH EUROPEAN COMPONENTS AND WE WISH THAT YOU ENJOY WITH ITS HIGH QUALITY AND PERFORMANCE.

• This system has been designed, fabricated and optimized by Pro DG Systems® in perfect working order. To maintain this condition and ensure the right operation, the user must respect the following indications and advices of this manual.

THE FIABILITY, SAFETY AND EFFICIENCY OF THE SYSTEM ARE ONLY AND EXCLUSIVELY GUARANTEED BY PRO DG SYSTEMS IF:

- Assembly, manipulation, re-adjustment and modifications or repairs are carried out by Pro DG Systems.
- The electrical installation complies with the requirements of IEC (ANSI).
- The system is used according to the use indications.

WARNING:

- If protectors are opened or sections of chassis are removed, except where this can be done manually, live parts can become exposed.
- Any adjustment, manipulation, optimization or reparation of the system must be done only and exclusively by Pro DG Systems. PRO DG SYSTEMS IS NOT RESPONSIBLE OF ANY DAMAGE OF THE SYSTEM CAUSED BY A MANIPULATION, ADJUSTMENT, OPTIMIZATION OR REPARATION REALIZED BY NO-AUTHORIZED PERSONAL BY PRO DG SYSTEMS
- High loudspeaker levels can cause hearing damage, it must avoid the direct contact with loudspeakers operating at high levels, otherwise it must use hearing protectors.

MAINS CONNECTION:

- The system is designed for continuous operation.
- The set operating voltage must match the local mains supply voltage.
- The units has to be connected to the mains via the supplied power unit or power cable.
- Power unit: never use a damaged connection lead. Any type of damage must be fixed.
- Avoid connection to the mains supply in distributor boxes together with several other power consumers.
- The plug socket for the power supply must be positioned near the unit and must be easily accessible.

PLACE OF SITUATION:

- The system should stand only on a clean and totally horizontal surface.
- The system must not be exposed to any type of vibration during its operation.
- Avoid the contact with the water or wet surfaces. Do not place objects containing liquid on the system.
- Procure that the system has sufficient ventilation and do not block or cover any ventilation opening. Obstruct the ventilation may cause overheating in the system.
- Avoid the direct exposition with the sun and proximity with sources of heat or radiation.
- If the system undergoes an extreme change in temperature may affect its operation, before starting the system hope it has reached room temperature.

Indicaciones de seguridad

Leer antes de usar el sistema y guardar para su uso posterior

Safety Indications

Please read it before use the system and keep for later use

ACCESORIOS:

- El sistema no debe colocarse encima de ningún soporte inestable que pueda causar daños personales o al sistema coloque el sistema sólo en un carro, rack, trípode, soporte recomendado o suministrado por Pro DG Systems siguiendo las indicaciones de instalación. El conjunto del sistema con el pedestal se debe mover con mucho cuidado. La aplicación de una fuerza desmesurada o un suelo irregular puede ocasionar la caída de todo el conjunto.
- Piezas adicionales: no utilice nunca piezas adicionales que no estén recomendadas por Pro DG Systems. El uso de piezas no recomendadas puede provocar accidentes y rotura del sistema.
- Para proteger el sistema de una tormenta o si éste no se supervisa o utiliza durante algún tiempo, se debe desconectar la clavija de la red. Así se evitan daños en el sistema a causa de un rayo y golpes de tensión en la red de corriente alterna.

SE RECOMIENDA AL USUARIO LEER ESTAS INSTRUCCIONES ANTES DE USAR EL SISTEMA Y GUARDAR PARA SU USO POSTERIOR.

PRO DG SYSTEMS NO SE RESPONSABILIZA DEL USO INADECUADO DEL SISTEMA POR PARTE DE PERSONAL NO AUTORIZADO SIN LOS SUFICIENTES CONOCIMIENTOS DE USO.

EL USO DE LOS PRODUCTOS PRO DG SYSTEMS ESTA INDICADO PARA LOS PROFESIONALES AUTORIZADOS QUE DEBEN POSEER LOS SUFICIENTES CONOCIMIENTOS DE USO DEL MISMO Y SIEMPRE RESPETANDO LAS INDICACIONES QUE SE MUESTRAN A CONTINUACION EN ESTE MANUAL.

ACCESSORIES:

- Do not place the system on a unsteady base that can be cause of damage to people or to the system, use it only with the trolley, rack, tripod or base recommended or supplied by Pro DG Systems following the installation indications. The system's combination must be moved very carefully.
- The application of an excessive use of force and uneven floors can cause the combination of system and stand to tip over.
- Additional equipment: don't use additional equipment wich has not be recommended by Pro DG Systems. The use of not recommended equipment can cause accidents and damage to the system.
- To protect the system during bad weather or when left unattended for prolonged periods, the main plug should be disconnected. This prevents the system being damaged by lightning and power surges in the AC mains supply.

IT IS RECOMMENDED TO THE USER READ THESE INSTRUCTIONS BEFORE USING THE SYSTEM AND SAVE FOR LATER USE.

PRO DG SYSTEMS IS NOT RESPONSIBLE OF AN INADEQUATE USE OF THE SYSTEM BY NO-AUTHORIZED PERSONNEL WITHOUT ENOUGH KNOWLEDGE OF USE.

THE USE OF THE PRO DG SYSTEMS PRODUCTS IS INDICATED FOR AUTHORIZED PROFESSIONALS THAT MUST TO HAVE ENOUGH KNOWLEDGE OF THE SYSTEM USE AND ALWAYS RESPECTING THE INDICATIONS SHOWN BELOW.



Pro DG Systems GTA 2X8 L.A.

Manual de uso - User manual

- I. **GTA 2X8 L.A.** Introducción / **Introduction.**
 - I.I. Descripción / **Description.** Pág. 1
 - I.II. Especificaciones Técnicas & Arquitecturales / **Technical & Architectural Specifications.** Pág. 2

- II. Interior del **GTA 2X8 L.A.** / **Inside the GTA 2X8 L.A.**
 - II.I. Características principales del Altavoz - Especificaciones Técnicas Parámetros - Información de montaje / **Speaker Key Features - Technical Specifications - Thiele - Small Parameters - Mounting information.** Pág. 3
 - II.II. Características principales de la Bocina de directividad constante del **GTA 2X8 L.A.** / **Key Features of GTA 2X8 L.A. Constant Directivity Horn** Pág. 4
 - II.III. Motores de compresión de **GTA 2X8 L.A.** Características principales (1 unidad) - Drivers de frecuencia & Curvas de distorsión - Curva de Impedancia - Dispersión Horizontal - Dispersión Vertical - Características técnicas - Dimensiones - Información de montaje - Materiales de construcción / **GTA 2X8 L.A. Compression Drivers. Key Features (1 unit) - Frequency Drivers & Distortion Curves - Impedance Curve - Horizontal & Vertical Dispersion - Technical Specifications - Dimensions Graph - Mounting information - Construction Materials** Pág. 5-6

- III. Amplificación de **GTA 2X8 L.A.** / **GTA 2X8 L.A. Amplification**
 - III.I. **GT 1.2 H** Especificaciones Técnicas / **GT 1.2 H Technical Specifications.** Pág. 7-8

| | | |
|------------|--|---------|
| IV. | Accesorios de montaje / Rigging Hardware | |
| | IV.I. Hardware de Vuelo / Flight Hardware | Pág. 9 |
| V. | Software de Predicción / Prediction Software | Pág. 10 |
| VI. | Equipamiento y Accesorios / Equipment and Accessories | Pág. 11 |

I. INTRODUCCION - INTRODUCTION

Este manual ha sido diseñado para ayudar a los usuarios del sistema **GTA 2X8 L.A.** de **Pro DG Systems** a la correcta utilización y al entendimiento de los beneficios y versatilidad del mismo. **GTA 2X8 L.A.** es un sistema line array totalmente diseñado, fabricado y optimizado en Europa (España), exclusivamente con componentes Europeos.

This manual is designed to help **GTA 2X8 L.A.** system users from **Pro DG Systems**, to the correct use and for the understanding of the benefits and versatilities of the same. **GTA 2X8 L.A.** is a line array system completely designed, manufactured and optimized in Europe (Spain), exclusively with European components.



GTA 2X8 L.A.

Totalmente diseñado, fabricado y optimizado en Europa (España) exclusivamente con componentes Europeos.

100% designed - fabricated - optimized in Europe (Spain) only and exclusively with European components.

I.I. DESCRIPCION - DESCRIPTION

Sistema line array autoamplificado de dos vías, equipado con dos altavoces de 8" en un recinto sintonizado. La sección de agudos cuenta con dos drivers de compresión de 1" acoplados a una guía de onda. La configuración del transductor, genera una cobertura horizontal simétrica de 120 °, sin lóbulos secundarios sobre el rango de frecuencia. Ideal para P.A. principal, Frontfill, Sidefill y Downfill, tanto en conciertos en directo al aire libre como para la instalación permanente.

Self-powered line array system of 2-ways, equipped with two (2) speakers of 8" in a tuning enclosure. The HF section has two (2) compression drivers of 1" coupled to a wave guide. The transducer configuration generates a symmetric and horizontal dispersion of 120 degrees without secondary lobes over the entire frequency range. Ideal for main P.A. Frontfill, Sidefill and Downfill both in outdoor events as well in permanent installation.



I.II. ESPECIFICACIONES - SPECIFICATIONS

| | |
|------------------------------------|---|
| Power Handling: | 700 W RMS (EIA 426A standard) 1400 W programme / 2800 W peak. |
| Nominal Impedence: | 4 Ohm |
| Average Sensitivity: | 100 dB / 2.83 V / 1m (average 100 - 18000 Hz wideband). |
| Calculated Maximum SPL: | / 1m 127 dB continuous / 130 dB programme / 133 dB peak. |
| Operative Frequency Range: | + /- 3 dB from 80 to 20000 Hz |
| Nominal Directivity: | 120° degrees horizontal, vertical dispersion depends on longitude or personalized configuration. |
| Low / Mid Frequency Driver: | 2 Beyma speakers (8"), 8 Ohm, 300 W, 200 mm (2") with high temperature voice coil on glass fibre former. |
| Mid Frequency Cut-off: | 90 Hz Linkwitz-riley 24 filter - 1200 Hz Linkwitz-riley 24 filter. |
| High Frequency Driver: | Two (2) Beyma drivers of 1", 8 Ohm, 50 W, 25 mm exit (44.4mm) with diaphragm voice coil meilar diaphragm. |
| High Frequency Cut-off: | 1200 Hz Linkwitz-riley 24 filter - 18000 Hz Linkwitz-riley 24 filter. |
| Recommended Amplifier: | Pro DG Systems GT 1.2 H into the Cabinet. |
| Connectors: | 2 X XLR + 1 NL4MP speakon connectors. USB-Ethernet + 2 X Powercom. |
| Acoustic Box: | CNC model, 15mm made from birch wood plated on the exterior. |
| Finish: | Standard black paint job. |
| Box Dimensions: | (HxWxD) 280x735x465mm (11,02"x28,94"x18,31"). |
| Weight: | 34,9 Kg (76,94 lbs) net / 36,1 Kg (79,59 lbs) gross weight with packing. |

ARCHITECTURAL SPECIFICATIONS

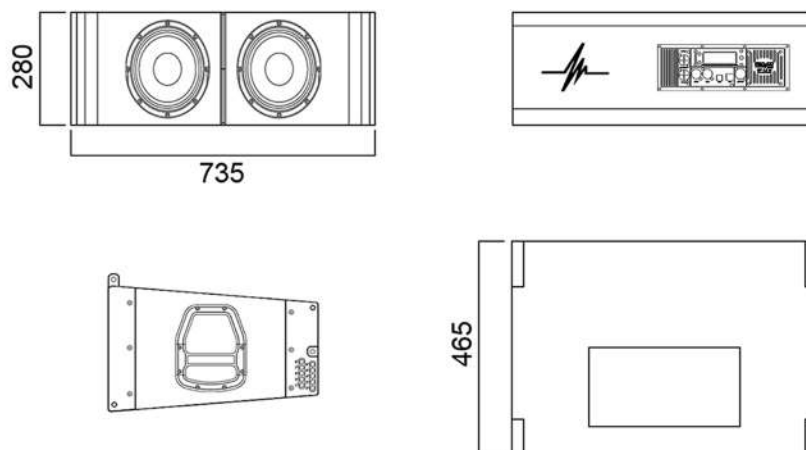

II. INTERIOR DE GTA 2X8 L.A. - INSIDE THE GTA 2X8 L.A.

El interior de GTA 2X8 L.A. está compuesto por 2 altavoces Beyma de 8" 300 W RMS. Especialmente diseñado bajo nuestros propios parámetros para el mejor rendimiento del sistema.

Inside the GTA 2X8 L.A. is composed by two (2) Beyma speakers of 8", 300 W RMS. Specially designed under our own parameters for the best performance of the system.

KEY FEATURES

- Excellent power and performance
- Extended controlled displacement: $X_{max} \pm 6$ mm
- Extended mechanical displacement capability
- Designed with MMSS technology for high control, symmetry and linearity with ferrite magnet
- Demodulating ring for low harmonic distortion
- CONEX spider for higher resistance and consistency
- Waterproof carbon fiber loaded paper cone with Santoprene™ surround

TECHNICAL SPECIFICATIONS

| | | |
|------------------------------------|-----------|-----------------------------|
| Nominal diameter | 200 mm | 8 in |
| Rated impedance | | 8 Ω |
| Minimum impedance | | 7,6 Ω |
| Power capacity | | 300 W RMS |
| Program power | | 600 W |
| Sensitivity | 95,4 dB | 2.83v @ 1m @ 2 π |
| Frequency range | | 65 - 6000 Hz |
| Recom. enclosure vol. | 10 / 30 l | 0,35 / 1,06 ft ³ |
| Voice coil diameter | | 51.7 mm. 2 in |
| Magnetic assembly weight | | 2.8 kg. 6.17 lb |
| BL factor | | 13 N / A |
| Moving mass | | 0.024 kg |
| Voice coil length | | 15 mm |
| Air gap height | | 7 mm |
| X _{damage} (peak to peak) | | 24 mm |

THIELE - SMALL PARAMETERS*

| | | |
|--|--|----------------------|
| Resonant frequency, f_s | | 65 Hz |
| D.C. Voice coil resistance, R_e | | 5,2 Ω |
| Mechanical Quality Factor, Q_{ms} | | 9,54 |
| Electrical Quality Factor, Q_{es} | | 0,34 |
| Total Quality Factor, Q_{ts} | | 0,33 |
| Equivalent Air Volume to C_{ms} , V_{as} | | 21,49 l |
| Mechanical Compliance, C_{ms} | | 318 μ m / N |
| Mechanical Resistance, R_{ms} | | 0,85 kg / s |
| Efficiency, η_0 | | 1,39 % |
| Effective Surface Area, S_d | | 0.022 m ² |
| Maximum Displacement, X_{max} *** | | 6 mm |
| Displacement Volume, V_d | | 100 m ³ |
| Voice Coil Inductance, L_e @ 1 kHz | | 0,8 mH |



Especialmente diseñado bajo nuestros propios parámetros para el mejor rendimiento del sistema.

Specially designed under our own parameters for the best performance of the system.

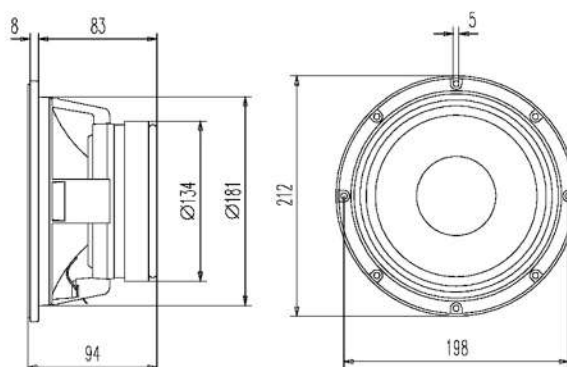

MOUNTING INFORMATION

| | | |
|----------------------------|---------|-----------------------|
| Overall diameter | 212 mm. | 8.35 in |
| Bolt circle diameter | 198 mm. | 7.8 in |
| Baffle cutout diameter: | | |
| - Front mount | 181 mm. | 7.12 in |
| - Rear mount | 183 mm. | 7.2 in |
| Depth | 94 mm. | 3.7 in |
| Volume displaced by driver | 1.5 l | 0.056 ft ³ |
| Net weight | 3.1 kg. | 6.83 lb |

* T-S parameters are measured after an exercise period using a preconditioning power test. The measurements are carried out with a velocity-current laser transducer and will reflect the long term parameters (when the loudspeaker has been working a short time).

** The X_{max} is calculated as: $(L_{vc} - Hag) / 2 + (Hag / 3,5)$, where L_{vc} is the voice coil length and Hag is the air gap eight.

INTERIOR DE GTA 2X8 L.A. - INSIDE THE GTA 2X8 L.A.

GTA 2X8 L.A. está compuesto además, por un bloque el cual conjuntamente con dos motores de compresión constituyen la bocina de directividad constante, específicamente diseñada para trabajar junto con dos motores de compresión Pro DG Systems de 50 W RMS, acoplados a una guía de ondas.

Las características de directividad constante de este modelo, aseguran poder cubrir 120° de amplitud horizontal y 20° de amplitud vertical, en prácticamente cualquier frecuencia dentro de su radio de acción. Para garantizar la libertad de resonancia está construido en aluminio con acabado de frente plano que facilita el montaje empotrado.

GTA 2X8 L.A. is also composed by one block which together with two (2) compression drivers, constitute the constant directivity horn, specifically designed to work with two (2) Pro DG Systems compression drivers of 50W RMS coupled to a waveguide.

The constant directivity characteristics of this model ensure the ability to cover 120° wide horizontally and 20° wide vertically at virtually any frequency within its operational range. To ensure freedom of resonance is constructed of aluminium with flat front finish to facilitate flush mounting.

KEY FEATURES

- Designed to be used with two Pro DG Systems compression drivers of 50 W RMS to a waveguide
- Provides uniform response
- Coverage of 120° in the horizontal plane and 20° in the vertical plane
- Precise directivity control in the pass band
- Aluminium construction with flat front to facilitate flush mounting



TECHNICAL SPECIFICATIONS

- **Horizontal beamwidth** 120° (+22°, -46°)
(-6 dB, 1.2 - 16 kHz)
- **Vertical beamwidth** 20° (+27°, -15°)
(-6 dB, 2 - 16 kHz)
- **Directivity factor (Q)** 60 (average 1.2 - 16 kHz)
- **Directivity index (DI)** 15.5 dB (+7 dB, -8.1 dB)
- **Cutoff frequency** 800 Hz
- **Dimensions (WxHxD)** 215x145x215mm.
8.46x5.71x8.46 in.
- **Net weight** 1 kg / 2.20 lb (total block weight).
- **Construction:** Aluminium.

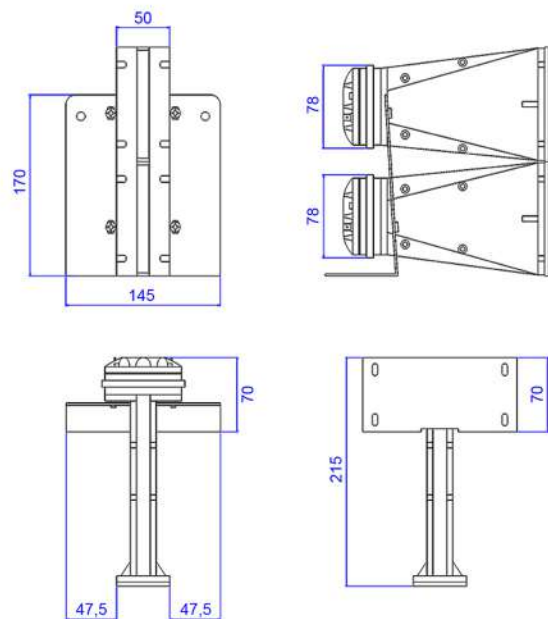

INTERIOR DE GTA 2X8 L.A. - INSIDE THE GTA 2X8 L.A.

GTA 2X8 L.A. está compuesto además por dos motores de compresión Beyma de 50 W RMS acoplados a una guía de onda. Especialmente diseñados bajo nuestros parametros para el mejor rendimiento del sistema.

Una combinación de motor de compresión de neodimio de alta potencia con la guía de onda proporciona la mejor combinación para el mejor desempeño de GTA 2X8 L.A. regulando el difícil problema de lograr un acoplamiento óptimo entre transductores de alta frecuencia adyacentes. En lugar de utilizar los dispositivos de conformación de onda caros y complicados, una guía de onda simple pero eficaz transforma la abertura circular del controlador de compresión en una superficie rectangular y sin ángulo de abertura excesiva para proporcionar baja curvatura de onda acústica, cumpliendo con el requisito de curvatura, para un óptimo acoplamiento acústico entre las fuentes adyacentes hasta 18 KHz. Esto se logra con la longitud mínima posible de baja distorsión pero sin ser demasiado corta, lo que provocaría fuertes interferencias de alta frecuencia.

GTA 2X8 L.A. is also composed by two (2) Beyma compression drivers of 50 W RMS, coupled to a wave guide. Specially designed under our own parameters for the best performance of the system.

A combination of high power neodymium compression driver with waveguide, provides the best junction for the best efficiency of GTA 2X8 L.A. Solving the hard problem of achieving an optimum coupling between adjacent high frequency transducers. Instead of using expensive and troublesome wave - shaping devices, a simple but effective waveguide transforms the circular aperture of the compression driver into a rectangular surface, without undue angle aperture to provide low curvature to the acoustic wavefront, arriving to fulfil the necessary curvature requirement for the optimal acoustic coupling joint between adjacent sources until 18 KHz. This is achieved, with the minimum possible length for low distortion, but without being excessively short, which would cause strong high frequency interferences.

KEY FEATURES (ONE UNIT)

- 4" x 0.5" rectangular exit
- Neodymium magnetic circuit for high efficiency.
- Effective acoustical coupling up to 18 kHz.
- True 105 dB sensitivity 1w @ 1m (averaged 1-7 kHz).
- Extended frequency range: 0.7 - 20 kHz.
- 1.75" voice coil with a power handling of 50 W RMS.



FREQUENCY DRIVERS & DISTORTION CURVES

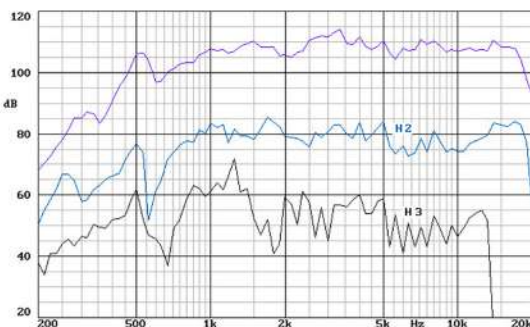

Note: on axis frequency response measured with 2 waveguides coupled to a 90° X 5° horn in an anechoic chamber, 1 w @ 1 m.

FREE AIR IMPEDANCE CURVE

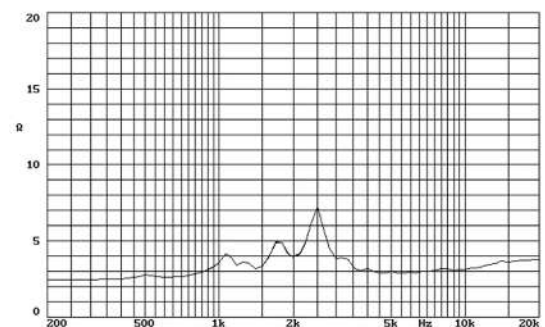

INTERIOR DE GTA 2X8 L.A. - INSIDE THE GTA 2X8 L.A.

HORIZONTAL DISPERSION

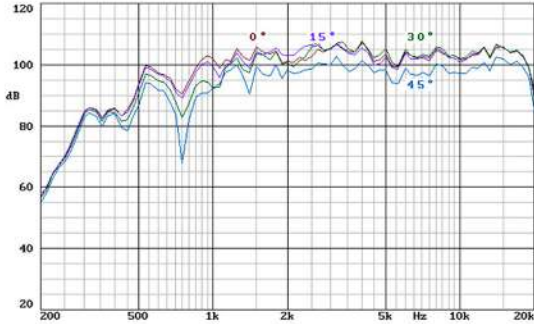

Notes: dispersion measured with two waveguides coupled to a 90° x 5° horn in anechoic chamber, 1w @ 2m.
All angle measurements are from the axis (45° means + 45°).

VERTICAL DISPERSION

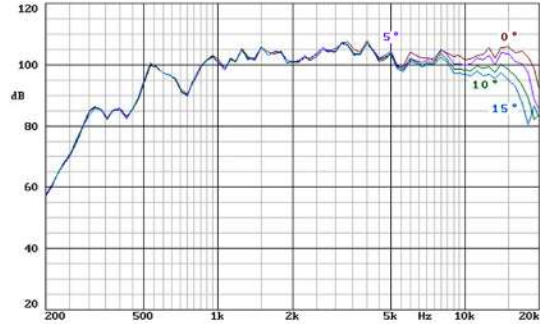

Notes: dispersion measured with two waveguides coupled to a 90° x 5° horn in anechoic chamber, 1w @ 2m.
All angle measurements are from the axis (45° means + 45°).

TECHNICAL SPECIFICATIONS

| | |
|--------------------------|---|
| Throat diameter | 20.5 mm. 0.8 in. |
| Rated impedance | 8 ohms. |
| Minimum impedance | 5.5 ohms. @ 4.5 kHz |
| D.C. Resistance | 5.6 ohms. |
| Power capacity | 50 W RMS above 1.5 kHz |
| Program power | 100 W above 1.5 kHz |
| Sensitivity * | 105 dB 1 w @ 1m coupled to a 90° x 5° horn |
| Frequency range | 0.7 - 20 kHz |
| Recommended crossover | 1500 Hz or higher (12 dB/oct. min.) |
| Voice coil diameter | 44.4 mm. 1.75 in. |
| Magnetic assembly weight | 0.6 kg. 1.32 lb. |
| Flux density | 1.8 T |
| BL factor | 8 N/A |

DIMENSION DRAWINGS

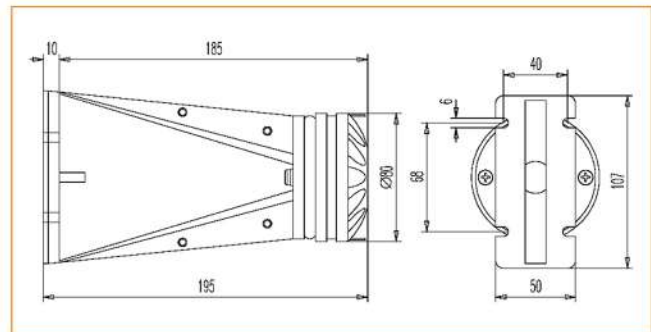

Note: * Sensitivity was measured at 1 m distance, on axis, with 1 w input, averaged in the range 1-7 KHz

MOUNTING INFORMATION

| | |
|---------------------------|---------------------------|
| Overall diameter | 80 mm. 3.15 in. |
| Depth | 195 mm. 7.68 in. |
| Mounting | Four 6 mm. diameter holes |
| Net weight (1 unit) | 1.1 kg. 2.42 lb. |
| Shipping weight (2 units) | 2.6 kg. 5.72 lb. |

CONSTRUCTION MATERIALS

- **Waveguide:** aluminium.
- **Driver diaphragm:** polyester.
- **Driver voice coil:** edgewound aluminium ribbon wire.
- **Driver voice coil former:** kapton.
- **Driver magnet:** neodymium.

III. AMPLIFICACION DE GTA 2X8 L.A. / **GTA 2X8 L.A.** **AMPLIFICATION**

GT 1.2 H es un módulo amplificador digital de última generación Clase D de 1400 W. Incorpora procesador digital con entrada y salida XLR + conector USB y Ethernet.

Ideal para realizar diferentes configuraciones entre sistemas y multiples aplicaciones.

GT 1.2 H is a Class-D digital amplifier of last generation with 1400 W. It includes digital processing with XLR input and output + USB and Ethernet connectors.

Ideal for different configurations between systems and multiple applications.



TECHNICAL SPECIFICATIONS

| | |
|----------------------------------|---|
| Output power per channel: | 1 x 1000 W @ 4 Ohm - 1 x 400 W @ 4 Ohm |
| Output Circuitry: | UMACTM Class D - full bandwidth PWM modulator with ultra low distortion |
| Output Voltage: | 70 Vp / 140 Vpp (unloaded) / Bridged 140 Vp / 280 Vpp (unloaded) |
| Amplifier Gain: | 26 dB |
| Signal To Noise-Ratio: | > 119 dB (A-weighted, 20 Hz - 20 kHz, 8 Ω load) |
| THD + N (typical): | < 0,05 % (20 Hz - 20 kHz, 8 Ω load, 3 dB below rated power) |
| Frequency Response: | 20 Hz - 20 kHz ± 0.15 dB (8 Ω load, 1 dB below rated power) |
| Damping Factor: | > 900 (8 Ω load, 1 kHz and below) |

| | |
|------------------------------------|--|
| Protection Circuits: | Short circuit protection, DC protection, under voltage protection, temperature protection, overload protection |
| Readouts for DSP / Network: | Protect/Disable (mute) Heatsink temperature Clip (each channel) |
| Power Supply: | UREC™ universal mains switch mode power supply with Power Factor Correction (PFC) and integral standby converter |
| Operation Voltage: | Universal Mains, 85 - 265 V Aux. Power for DSP ± 15 V (100 mA), + 7.5 V (500 mA) |
| Standby Consumption: | < 1 W (Green Energy Star compliant) |
| Dimensions (HxWxD): | 106 x 296 x 105 mm / 4.17 x 11.65 x 4.13 in |
| Weight: | 1,28 kg / 2,82 lbs |

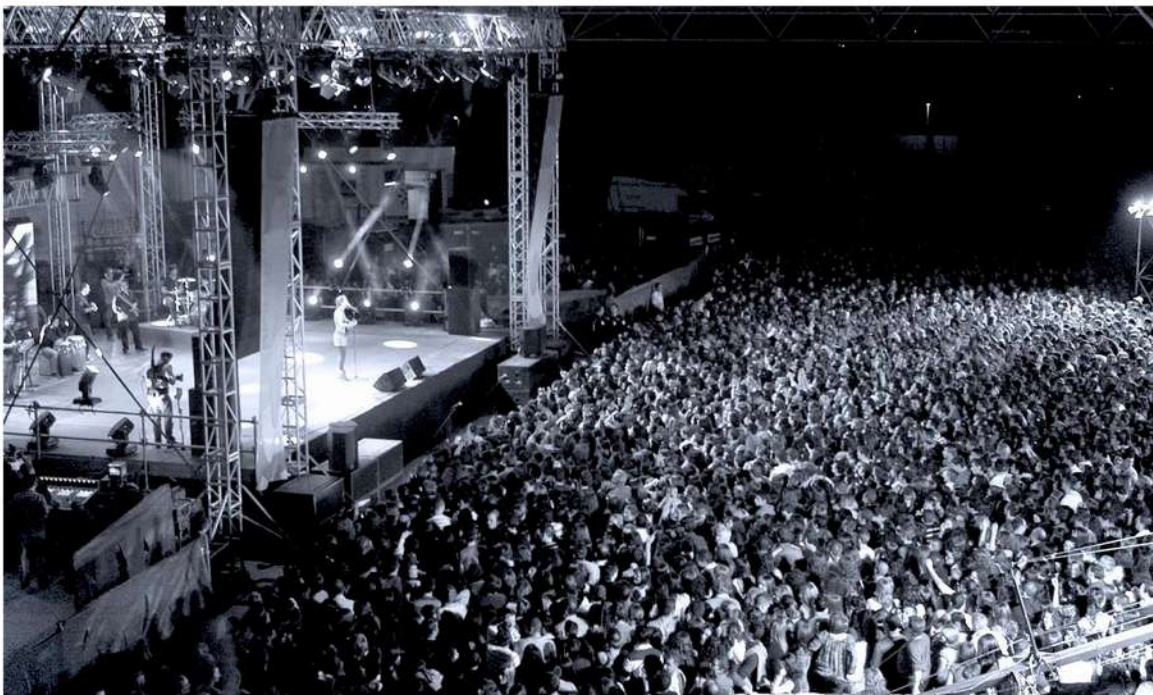

IV. HARDWARE DE VUELO - RIGGING HARDWARE



Hardware de vuelo para GTA 2X8 L.A. compuesto por: un marco de acero ligero + 4 pinlock + un grillete para soportar un peso máximo de una tonelada y media. Puede elevar hasta un total de 16 unidades GTA 2X8 L.A.

Rigging Hardware frame for GTA 2X8 L.A. composed by: one lightweight steel frame + 4 pinlock + one shackle to support a maximum weight of one ton and a half. Can elevate up a total number of 16 GTA 2X8 L.A.

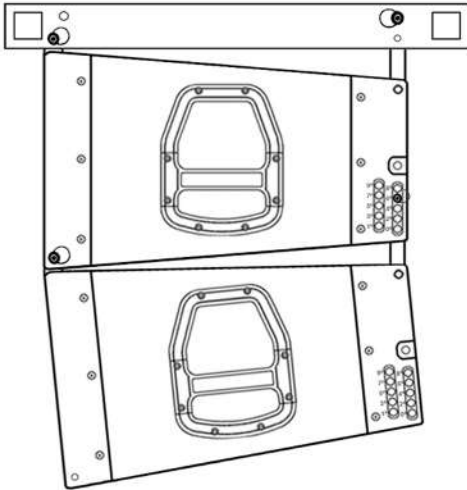

Hardware de vuelo incorporado en la caja con diferentes grados de angulación / Flight Hardware incorporated into the cabinet with different angulation grades.

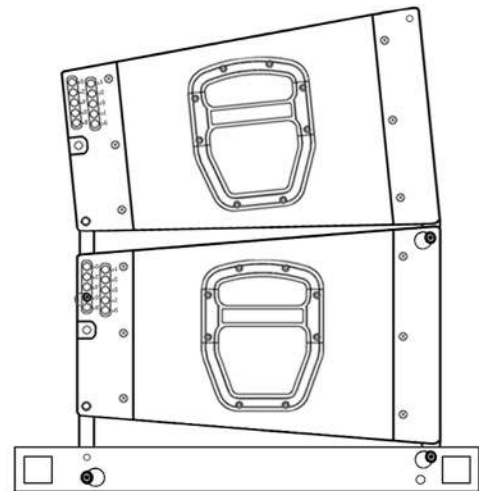

Modo estacado para la máxima versatilidad y cobertura / Stack mode for offer the maximum versatility and coverage.

IMPORTANTE: el uso incorrecto del marco y los componentes puede ser motivo de la formación de grietas que podrían poner en peligro la seguridad de un array. El uso de un cuadro y componentes dañados podría dar lugar a graves accidentes.

IMPORTANT: a misuse of the frame and components can be motive of cracking that could compromise the safety of an array. Using a damaged frame and components could result in serious mishaps.

V. SOFTWARE DE PREDICCIÓN Y HERRAMIENTAS DE INTEGRACION - PREDICTION SOFTWARE AND INTEGRATION TOOLS

En **Pro DG Systems** sabemos que fabricar cajas acústicas de buena calidad es una parte importante del trabajo. La garantía de poder utilizarlos adecuadamente, es la otra parte fundamental del trabajo que hemos realizado. Las buenas herramientas marcan la diferencia para lograr un óptimo uso de los sistemas.

GTA 2X8 L.A. dispone de Software de Predicción Ease Focus, con el cual podemos simular el rendimiento de diferentes sistemas en distintos lugares y circunstancias además de poder como ver cobertura, frecuencia, SPL y comportamiento general del sistema, de una manera sencilla y cómoda para el usuario. Muy fácil de manejar y disponemos de cursos de entrenamiento para los usuarios de productos **Pro DG Systems**. Para más información consulte con nuestro servicio técnico en: info@prodgsystems.com

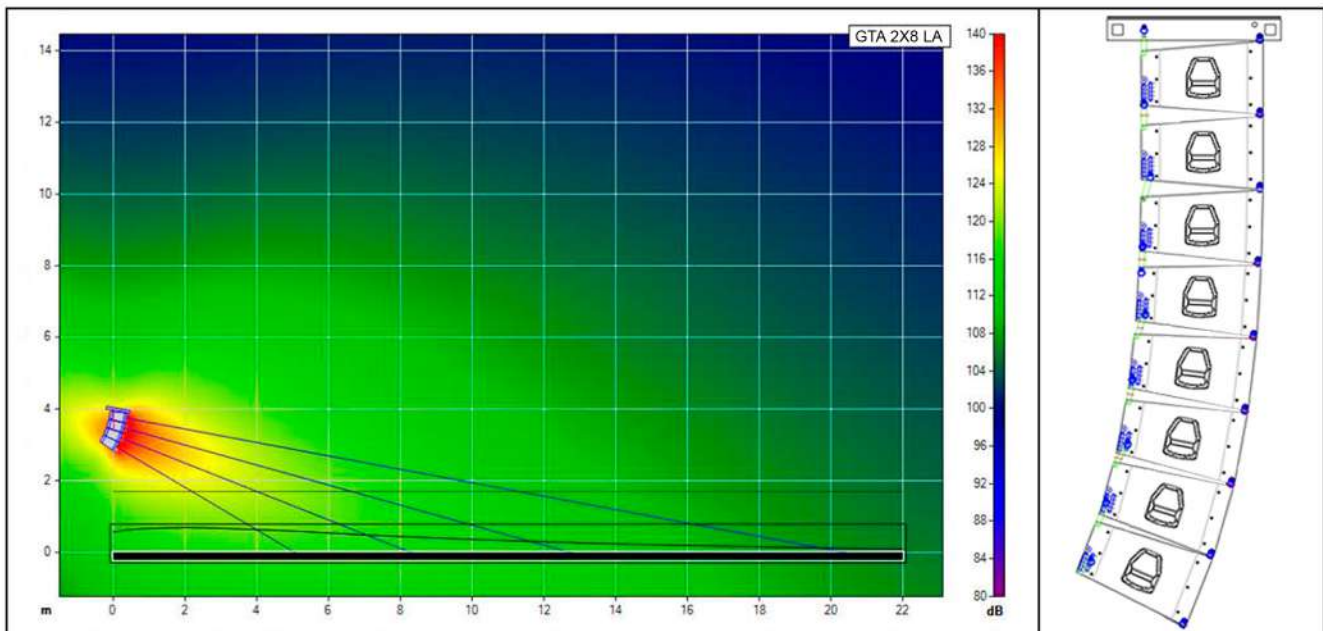

In **Pro DG Systems** we know that making good quality speakers is an important part of our job. Then, there is the other part that it is also fundamental in our job which is offering the warranty of using the speakers properly. Good tools make the difference to an optimal use of the system.

With the **GTA 2X8 L.A.** prediction software Ease Focus we can design different configurations between systems and simulate their behavior in different places and circumstances, like watching coverage, frequency, SPL and general systems behavior in an easy and comfortable way. It is easy to handle and we offer training courses for **Pro DG Systems** customers. For more information consult with our technical service at: info@prodgsystems.com

VI. ACCESORIOS - ACCESSORIES

Pro DG Systems ofrece a sus clientes todo tipo de equipamiento y accesorios para sus sistemas. **GTA 2X8 L.A.** dispone de flight case de transporte o patín y funda para el transporte además de cableado completo del sistema listo para funcionar.

Pro DG Systems offers to their customers all type of accessories for their systems. **GTA 2X8 L.A.** has F / Case for transport or Dolly Board and Covers for transport, plus complete cabling for the system ready to use.



Flight Case de transporte para cuatro unidades del **GTA 2X8 L.A.** Completamente dimensionado para el embalaje hermético y listo para la carretera.

Flight Case to transport four units of **GTA 2X8 L.A.** Fully dimensioned for an hermetic packaging and ready for the road.



Patín y funda para transportar cuatro unidades del **GTA 2X8 L.A.** Perfectamente dimensionado para el transporte en cualquier tipo de camión.

Dolly board and covers for transport four units of **GTA 2X8 L.A.** Perfectly dimensioned to transport in any type of truck.



Disponibile cableado completo del sistema listo para funcionar.
Entire cabling for the system available and ready for operation.



PRO DG SYSTEMS INTERNATIONAL

P.I. Santa Bárbara. C/ Aceituneros nº7
41580 Casariche (Sevilla). Spain

Phone: + 34 954 011 095

E-mail: info@prodgsystems.com
export@prodgsystems.com

Web: www.prodgsystems.com

 SOMETHING IS CHANGING